

Profipress G Instructions for Use

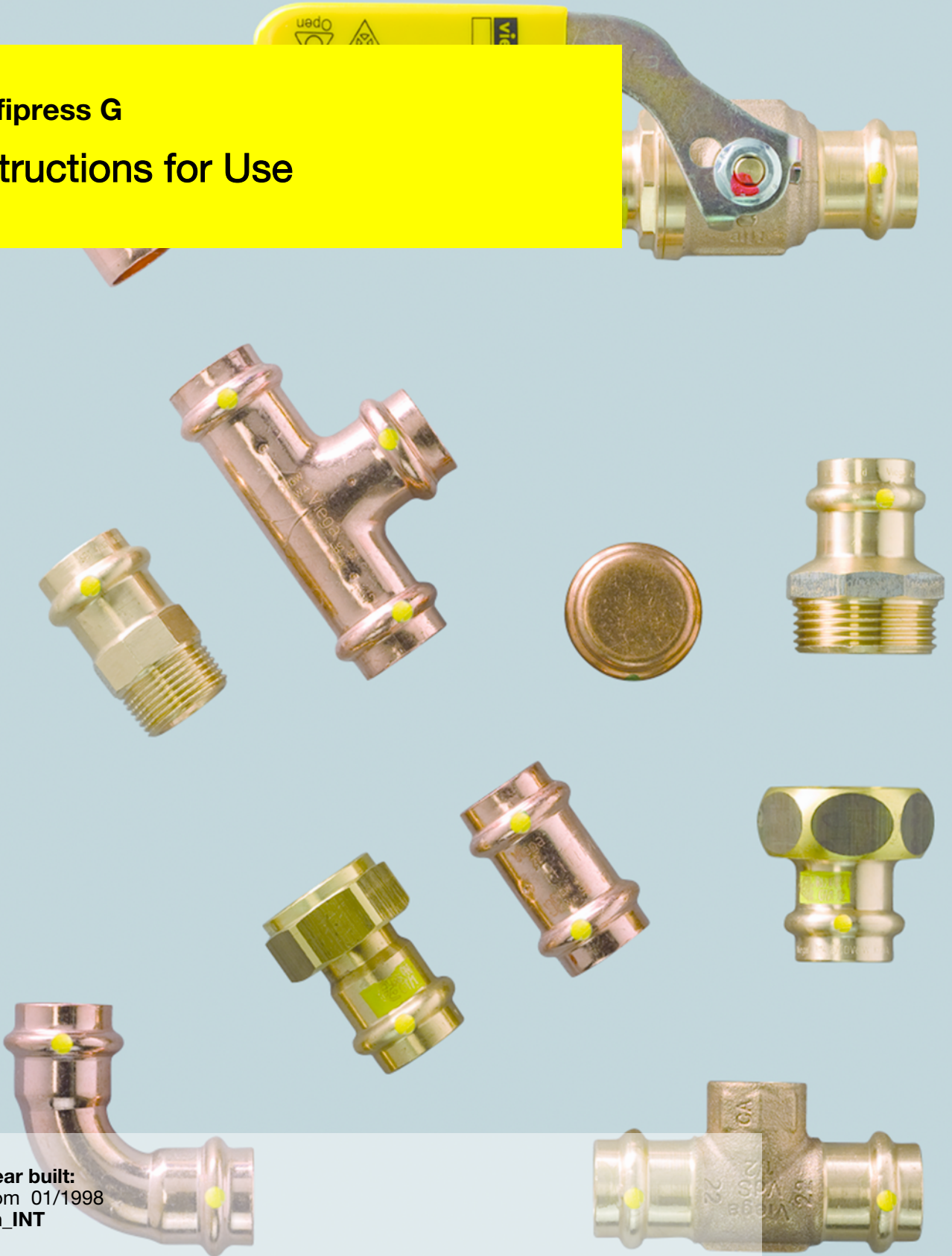

Year built:
from 01/1998
en_INT



Table of contents

1	About these instructions for use	4
1.1	Target groups	4
1.2	Labelling of notes	4
1.3	About this translated version	5
2	Product information	6
2.1	Standards and regulations	6
2.2	Intended use	8
2.2.1	Areas of use	8
2.2.2	Media	9
2.3	Product description	9
2.3.1	Overview	9
2.3.2	Pipes	10
2.3.3	Press connectors	11
2.3.4	Sealing elements	13
2.3.5	Markings on components	13
2.4	Information for use	14
2.4.1	Corrosion	14
3	Handling	15
3.1	Transport	15
3.2	Storage	15
3.3	Assembly information	15
3.3.1	Mounting instructions	15
3.3.2	Permitted exchange of sealing elements	17
3.3.3	Space requirements and intervals	17
3.3.4	Required tools	19
3.4	Assembly	20
3.4.1	Replacing the sealing element	20
3.4.2	Bending pipes	21
3.4.3	Shortening the pipes	21
3.4.4	Deburring the pipes	22
3.4.5	Pressing the connection	23
3.4.6	Leakage test	24
3.5	Maintenance	24
3.6	Disposal	25

1 About these instructions for use

Trade mark rights exist for this document, further information can be found at viega.com/legal.

1.1 Target groups

The information in this instruction manual is directed at the following groups of people:

- contract installers registered in the installers' register of a utility company
- professional specialist companies for the construction, maintenance and alteration of a natural or liquid gas system

Liquid gas systems may only be constructed, maintained or altered by companies that have the necessary qualification and experience.

It is not permitted for individuals without the abovementioned training or qualification to mount, install and, if required, maintain this product. This restriction does not extend to possible operating instructions.

The installation of Viega products must take place in accordance with the general rules of engineering and the Viega instructions for use.

1.2 Labelling of notes

Warning and advisory texts are set aside from the remainder of the text and are labelled with the relevant pictographs.



DANGER!

This symbol warns against possible life-threatening injury.



WARNING!

This symbol warns against possible serious injury.



CAUTION!

This symbol warns against possible injury.



NOTICE!

This symbol warns against possible damage to property.



Notes give you additional helpful tips.

1.3 About this translated version

This instruction for use contains important information about the choice of product or system, assembly and commissioning as well as intended use and, if required, maintenance measures. The information about the products, their properties and application technology are based on the current standards in Europe (e. g. EN) and/or in Germany (e. g. DIN/DVGW).

Some passages in the text may refer to technical codes in Europe/Germany. These should serve as recommendations in the absence of corresponding national regulations. The relevant national laws, standards, regulations, directives and other technical provisions take priority over the German/European directives specified in this manual: The information herein is not binding for other countries and regions; as said above, they should be understood as a recommendation.

2 Product information

2.1 Standards and regulations

The following standards and regulations apply to Germany / Europe. National regulations can be found on the relevant web site of your country at viega.com/standards.

Regulations from section: Fields of application

Scope / Notice	Regulations
Planning, execution, modification and operation of gas installations	DVGW-TRGI 2008
Gas installations for industrial, commercial and process plants	DVGW-Arbeitsblatt G 5614
Gas installations for industrial, commercial and process plants	DVGW-Arbeitsblatt G 462
Gas installations for industrial, commercial and process plants	DVGW-Arbeitsblatt G 459-1
Gas installations for industrial, commercial and process plants	DVGW-Fachinformation Nr. 10
Planning, execution, modification and operation of liquid gas installations	DVFG-TRF 2012

Regulations from section: Media

Scope / Notice	Regulations
Suitability for gasses Liquid gas in the gaseous state	DVGW-Arbeitsblatt G 260
Suitability for fuel oil	DIN 51603-1
Suitability for Diesel fuel	DIN EN 590

Regulations from section: Pipes

Scope / Notice	Regulations
Rules of the fixing technology for gas installations	DVGW-TRGI 2008, Point 5.3.7
Rules of the fixing technology for gas installations	DVFG-TRF 2012, Point 7.3.6
Approval of press connectors for use with copper pipes	DVGW G 5614
Approval of press connectors for use with copper pipes	DIN EN 1057
Approval of press connectors for use with copper pipes	DVGW-Arbeitsblatt GW 392

Regulations from section: Corrosion

Scope / Notice	Regulations
(Subsequent) corrosion protection measures for laying in the ground	DIN 30672
Corrosion protection measures for external pipelines	DVGW-TRGI 2008, Point 5.2.7.1
Corrosion protection measures for internal pipelines	DVGW-TRGI 2008, Point 5.2.7.2
Corrosion protection measures for external pipelines	DVFG-TRF 2012, Point 7.2.7.1
Corrosion protection measures for internal pipelines	DVFG-TRF 2012, Point 7.2.7.2
Overground pipelines in recesses in the bare floor or levelling layer	DVGW-TRGI 2008, Point 5.3.7.8.4

Regulations from section: Storage

Scope / Notice	Regulations
Requirements for material storage	DIN EN 806-4, Chapter 4.2

Regulations from section: Notes on mounting

Scope / Notice	Regulations
The general rules of mounting for gas installations	DVGW-TRGI 2008, Point 5.3.7
The general rules of mounting for gas installations	DVFG-TRF 2012, Point 7.3.6

Regulations from section: Leakage test

Scope / Notice	Regulations applicable in Germany
Leakage test for gas installation	DVGW-TRGI 2008, Point 5.6
Testing and initial commissioning of a liquid gas system	DVFG-TRF 2012, Point 8

Regulations from section: Maintenance

Scope / Notice	Regulations
Ensuring and maintaining a safe operating condition of gas installations	DVGW-TRGI 2008, Appendix 5c

2.2 Intended use



Agree the use of the system for areas of use and media other than those described with the Viega Service Center.

2.2.1 Areas of use

Use is possible in the following areas among others:

- Gas installations
- Liquid gas systems
- Heating oil pipelines
- Diesel pipes
- Compressed air systems

Gas installation

For planning, execution, modification and operation of gas installations, observe the applicable regulations, see  „Regulations from section: Fields of application“ on page 6.

Use is possible in the gas installations described below:

- Gas installations
 - low pressure range ≤ 100 hPa (100 mbar)
 - medium pressure range from 100 hPa (100 mbar) up to 0.1 MPa (1 bar)
 - industrial, commercial and process technical systems with the corresponding directives and technical regulations
- Liquid gas systems
 - with liquid gas tank in medium pressure range downstream of the pressure regulating valve, 1st level on the liquid gas tank > 100 hPa (100 mbar) up to a permitted operating pressure of 0.5 MPa (5 bar)
 - with liquid gas tank in the low pressure range ≤ 100 hPa (100 mbar) behind the pressure regulating valve, 2nd level
 - with liquid gas pressurised container (liquid gas bottles) < 16 kg behind the small bottle pressure regulating valve
 - with liquid gas tank (liquid gas bottle) ≥ 16 kg behind the large bottle pressure regulating device



The Sanpress Inox G system must be used for liquid gas installations in areas with requirements of higher thermal resistance (HTR), with a pick-up pressure of the SSV > 0.1 MPa (1 bar).

2.2.2 Media

The system is suitable for the following media, amongst others:

For the applicable directives, see  „Regulations from section: Media“ on page 6.

- Gases
- Liquid gases, only in the gaseous state for domestic and commercial applications
- Fuel oil
- Diesel fuel
- Compressed air

2.3 Product description

2.3.1 Overview

The piping system consists of press connectors for copper pipes and the corresponding press tools.



Fig. 1: Profipress G press connectors

The system components are available in the following dimensions:
d 12 / 15 / 18 / 22 / 28 / 35 / 42 / 54.

2.3.2 Pipes

Profipress G press connectors are tested and certified with the following copper pipes, see [Chapter 2.1 „Standards and regulations“](#) on page 6:

Thinner walls than stated are not permitted.

d x s [mm]	Volume per metre of pipe [l/m]	Pipe weight [kg/m]
12 x 0.8	0.09	0.25
12 x 1.0	0.08	0.31
15 x 1.0	0.13	0.39
18 x 1.0	0.20	0.48
22 x 1.0	0.31	0.59
28 x 1.0	0.53	0.76
28 x 1.5	0.49	1.11
35 x 1.2	0.84	1.13
35 x 1.5	0.80	1.41
42 x 1.2	1.23	1.37
42 x 1.5	1.20	1.70
54 x 1.5	2.04	2.20
54 x 2.0	1.96	2.91

Laying and fixing pipes

Observe the general rules of fixing technology:

- For gas installations, see ↗ *Chapter 2.1 „Standards and regulations“ on page 6.*
- Only fix on components with sufficient stability.
- Gas supply lines must not be secured to other pipelines nor should they be used as support for other pipelines.
- The system can be secured using commercially available plastic dowels together with non-flammable pipe clamps (e. g. metallic pipe clamps).

With gas supply lines, observe the following fixing intervals for pipelines laid horizontally:

Interval between the pipe clamps

d [mm]	Fixing interval between the pipe clamps [m]
12.0	1.25
15.0	1.25
18.0	1.50
22.0	2.00
28.0	2.25
35.0	2.75
42.0	3.00
54.0	3.50

2.3.3 Press connectors

Press connectors are available in a number of shapes. An overview of the press connectors suitable for the system can be found in the catalogue.

The press connectors in the Profipress G system consist of the following materials:

- copper
- gunmetal



Fig. 2: Press connectors

The press connectors have a circumferential bead in which the sealing element lies. The connector is deformed upstream and downstream of the bead and permanently connected to the pipe during pressing. The sealing element is not deformed during pressing.

SC-Contur

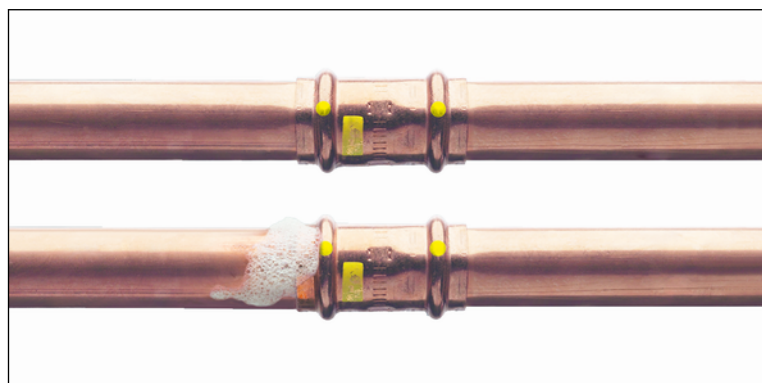

Fig. 3: SC-Contur

Viega press connectors are equipped with the SC-Contur. The SC-Contur is a safety technology that is certified by the DVGW and ensures that the connector is guaranteed to be leaky in an unpressed state. In this way, inadvertently unpressed connections are noticed immediately during a leakage test.

Viega guarantees that unpressed connections are visible during a leakage test:

- with dry leakage test in the pressure range from 22 hPa–0.3 MPa (22 mbar–3.0 bar)

2.3.4 Sealing elements

The press connectors are factory-fitted with yellow HNBR sealing elements.

Use	Gas installation	Liquid gas installation	Heating oil and diesel pipelines
Operating temperature	-20 °C up to +70 °C	-20 °C up to +70 °C	≤ 40 °C
Operating pressure	≤ 0.5 MPa (5 bar) (MOP 5) ≤ 0.1 MPa (1 bar) (HTR / GT1) ²⁾	≤ 0.5 MPa (5 bar) (MOP 5) ¹⁾ ≤ 0.1 MPa (1 bar) (HTR / GT1) ²⁾	≤ 0.5 MPa (5 bar)

¹⁾ The maximum pressure equates to the pick-up pressure of the SSV in the pressure regulating valve.

²⁾ GT1: Operating pressure at HTR requirement 650 °C / 30 min max. 0.1 MPa (1 bar)

2.3.5 Markings on components

Markings on press connectors

The press connectors are marked with a coloured dot. This identifies the SC-Contur, where the test medium would escape in the case of an inadvertently unpressed connection.



Fig. 4: Marking on the press connector

The press connectors are marked as follows:

- yellow dot and yellow rectangle for gas
- *Gas* for gas supply lines
- *MOP5* for maximum operating pressure 0.5 MPa (5 bar)
- *GT1* for operating pressure with HTR requirement 0.1 MPa (1 bar)
- *ATG* for certification in France
- *Gastec* for certification in the Netherlands
- *T2* for certification in Poland
- DVGW
- KIWA

2.4 Information for use

2.4.1 Corrosion

Depending on the area of use, corrosion protection measures may have to be taken into account. One differentiates between external pipelines (underground and overground external pipelines), as well as internal pipelines.

Information about the area of use, also see ↪ *Chapter 2.2.1 „Areas of use“ on page 8.*

The pertinent guidelines must be observed for corrosion protection, see ↪ *„Regulations from section: Corrosion“ on page 7.*

Overground pipes and fittings in rooms do not normally require external corrosion protection.

There are exceptions in the following cases:

- There is contact with aggressive building materials such as materials containing nitrite or ammonium.
- in aggressive surroundings
- In recesses within bare floors or in the compensating layer, they must be treated in the same way as buried external pipelines, see ↪ *„Regulations from section: Corrosion“ on page 7.*

3 Handling

3.1 Transport

Observe the following when transporting pipes:

- Do not pull the pipes over the sill. The surface could be damaged.
- Secure pipes during transportation. Pipes may become bent due to shifting.
- Do not damage the protective caps on the pipe ends and do not remove them until immediately before mounting. Damaged pipe ends may not be pressed.



In addition, observe the instructions provided by the pipe manufacturer.

3.2 Storage

For storage, comply with the requirements specified in the applicable regulations, see [☞ „Regulations from section: Storage“ on page 7](#):

- Store components in a clean and dry place.
- Do not store the components directly on the floor.
- Provide at least three points of support for the storage of pipes.
- Where possible, store different sizes separately.
Store small sizes on top of larger sizes if separate storage is not possible.



In addition, observe the instructions provided by the pipe manufacturer.

3.3 Assembly information

3.3.1 Mounting instructions

Checking system components

System components may, in some cases, become damaged through transportation and storage.

- Check all parts.
- Replace damaged components.
- Do not repair damaged components.
- Contaminated components may not be installed.

The system is intended for underground device connection pipelines for gas devices for use outside. Press connectors are not permitted in underground liquid gas pipelines.

For gas installations, observe the applicable regulations, see  „Regulations from section: Notes on mounting“ on page 7.



NOTICE!

Active and possibly passive protection measures are required to protect a gas installation from tampering by unauthorised persons, see  „Regulations from section: Notes on mounting“ on page 7.

Active protective measures (e. g. gas flow monitor) must always be taken.

Passive protective measures (e.g. gas safety plugs and caps) must be selected and employed depending on the installation.

The general rules of mounting for gas supply lines

The following conditions amongst others are valid when laying gas supply lines:

- Lay gas supply lines with clearance from the installation body, concealed without hollow spaces or in ventilated ducts or shafts.
- Do not install gas supply lines with operating pressures > 100 hPa (100 mbar) concealed in the wall.
- Arrange gas supply lines in such a way that condense water or water dripping from other pipes and components does not affect them.
- Do not lay gas supply lines in screed.
- Shut-off systems and detachable connections must be easily accessible.

Requirements on concealed installations:

- Lay stress-free.
- Apply corrosion protection.
- Do not use any detachable connections (screw fittings).
- Do not use copper pipes together with materials containing nitrite or ammonium.



Continuous, connection-free gas supply lines may be laid in hollow spaces (pre-wall constructions) to be connected to a gas device or a gas socket.

Ventilation is not required.

3.3.2 Permitted exchange of sealing elements



Important instruction

With their material-specific qualities, sealing elements in press connectors are adapted for use with the corresponding media and/or the areas of use of the piping systems and are generally only certified for them.

The exchange of a sealing element is generally permitted. The sealing element must be replaced by a sealing element of the same material ↪ Chapter 2.3.4 „Sealing elements“ on page 13. The use of other sealing elements is not permitted.

If the sealing element in the press connector is obviously damaged, it should be exchanged for a Viega replacement sealing element made of the same material.

3.3.3 Space requirements and intervals

Pressing between pipelines

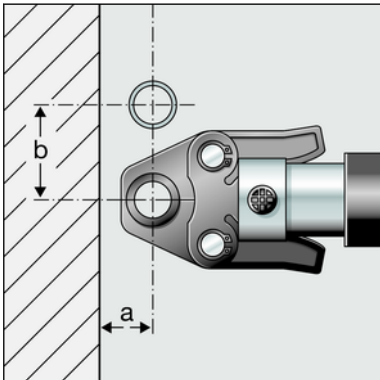

Space requirement PT1, type 2 (PT2), PT3-EH, PT3-AH, Pressgun 4B, 4E, 5

d	12	15	18	22	28	35	42	54
a [mm]	20	20	20	25	25	30	45	50
b [mm]	50	50	55	60	70	85	100	115

Space requirement Picco, Pressgun Picco

d	12	15	18	22	28	35
a [mm]	25	25	25	25	25	25
b [mm]	55	60	60	65	65	65

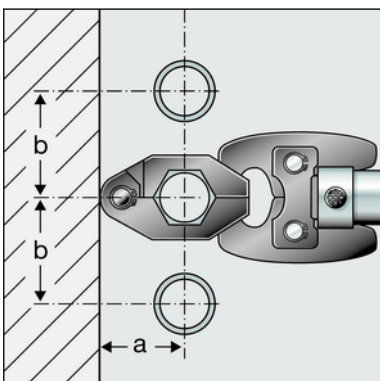

Space requirement press ring

d	12	15	18	22	28	35	42	54
a [mm]	40	40	45	45	50	55	60	65
b [mm]	45	50	55	60	70	75	85	90

Pressing between pipe and wall

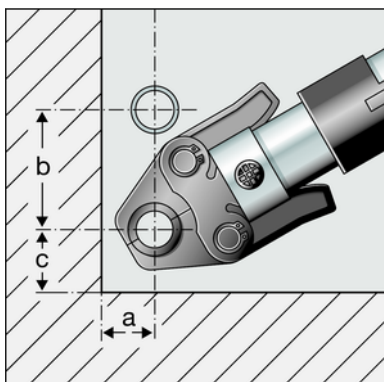

Space requirement PT1, type 2 (PT2), PT3-EH, PT3-AH, Pressgun 4B, 4E, 5

d	12	15	18	22	28	35	42	54
a [mm]	25	25	25	30	30	50	50	55
b [mm]	65	65	75	80	85	95	115	140
c [mm]	40	40	40	40	50	50	70	80

Space requirement Picco, Pressgun Picco

d	12	15	18	22	28	35
a [mm]	30	30	30	30	30	30
b [mm]	70	70	70	75	80	80
c [mm]	40	40	40	40	40	40

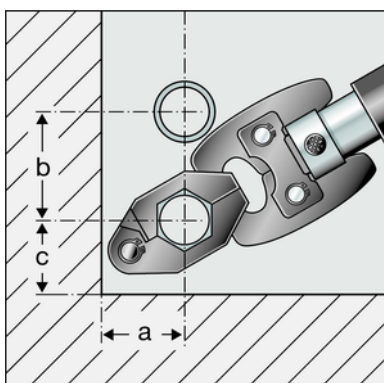

Space requirement press ring

d	12	15	18	22	28	35	42	54
a [mm]	40	40	45	45	50	55	60	65
b [mm]	45	50	55	60	70	75	85	90
c [mm]	35	35	40	40	45	50	55	65

Distance to walls

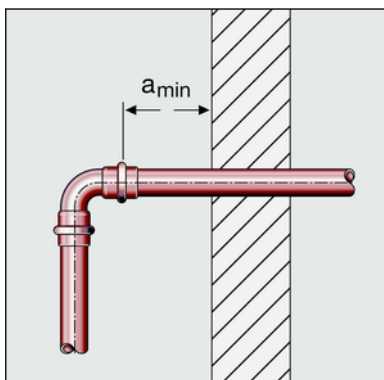

Minimum interval with d 12–54

Press machine	a_{min} [mm]
PT1	45
Type 2 (PT2)	50
Type PT3-EH	
Type PT3-AH	
Pressgun 4E / 4B	
Pressgun 5	
Picco / Pressgun Picco	35

Interval between the pressings



NOTICE!

Leaky press connections due to pipes being too short

If two press connectors are to be mounted next to one another onto a pipe without an interval, the pipe must not be too short. If the pipe is not inserted up to the prescribed insertion depth in the press connector during pressing, the connection may become leaky.

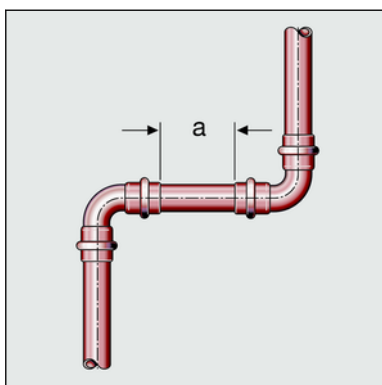

Minimum interval with press jaws d 12–54

d	a_{\min} [mm]
12	0
15	0
18	0
22	0
28	0
35	10
42	15
54	25

Z dimensions

The Z dimensions can be found at www.viega.de.

3.3.4 Required tools

The following tools are required for production of a press connection:

- pipe cutter or a fine-toothed hacksaw
- deburrer and coloured pen for marking
- press machine with constant pressing force
- press jaw or press ring with corresponding adapter jaw, suitable for the pipe diameter and suitable profile



Fig. 5: Press jaws

Recommended Viega press machines:

- Pressgun 5
- Pressgun Picco
- Pressgun 4E / 4B
- Picco
- Type PT3-AH
- Type PT3-H / EH
- Type 2 (PT2)

3.4 Assembly

3.4.1 Replacing the sealing element

Removing the sealing element



Do not use pointed or sharp-edged objects to remove the sealing element. These could damage the sealing element or bead.

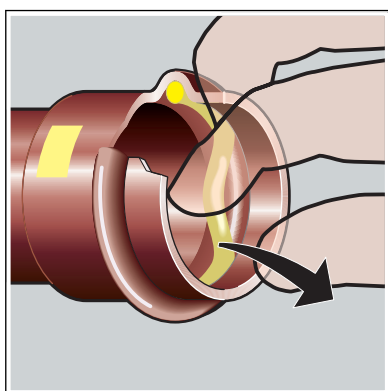

- Remove the sealing element from the bead.

Inserting the sealing element

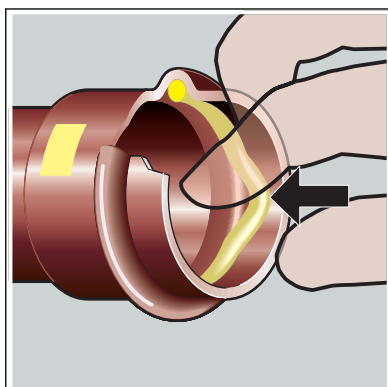

- Insert a new, undamaged sealing element into the bead.
- Ensure that the complete sealing element is in the bead.

3.4.2 Bending pipes

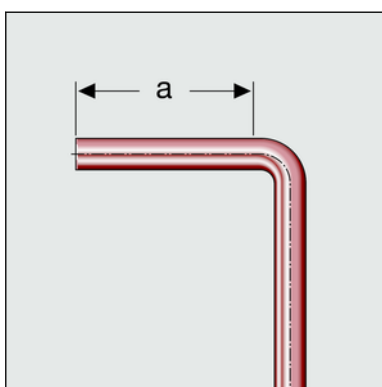

Copper pipes in the sizes d 12, 15, 18, 22 and 28 can be bent cold with commercially available bending equipment (radius at least $3.5 \times d$).

The pipe ends (a) must be at least 50 mm long so that the press connectors can be mounted properly.

3.4.3 Shortening the pipes



NOTICE!

Leaky press connections due to damaged material!

Press connections can become leaky due to damaged pipes or sealing elements.

Observe the following instructions to avoid damage to pipes and sealing elements:

- Do not use cutting discs (angle grinders) or flame cutters when cutting to length.
- Do not use grease or oils (e. g. cutting oil).

For information about tools, also see [Chapter 3.3.4 „Required tools“](#) on page 19.

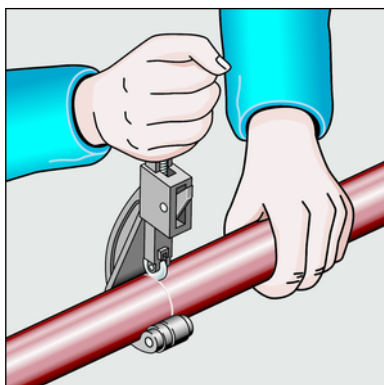

- Cut the pipe properly using a pipe cutter or fine-toothed hacksaw. Avoid grooves on the pipe surface.

3.4.4 Deburring the pipes

The pipe ends must be thoroughly deburred internally and externally after shortening.

Deburring prevents the sealing element being damaged or the that the press connector cants when mounted. Use of a deburrer (model 2292.2) is recommended.



NOTICE!
Damage due to the wrong tool!

Do not use sanding disks or similar tools when deburring. The pipes could be damaged by these.

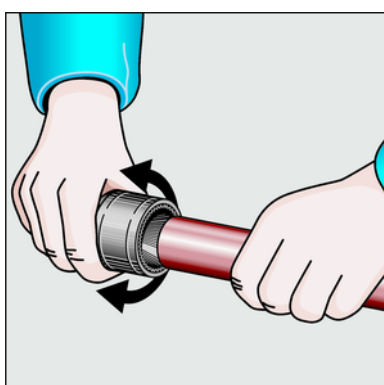

- Deburr the inside and outside of the pipe.

3.4.5 Pressing the connection

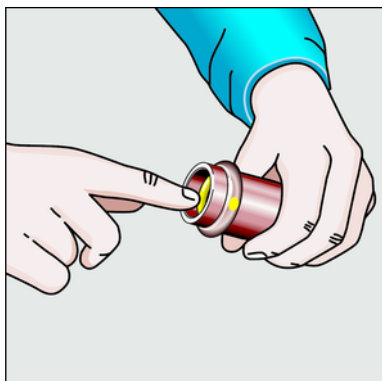

Requirements:

- The pipe end is not bent or damaged.
- The pipe is deburred.
- The correct sealing element is in the press connector.
HNBR = yellow
- The sealing element is undamaged.
- The complete sealing element is in the bead.

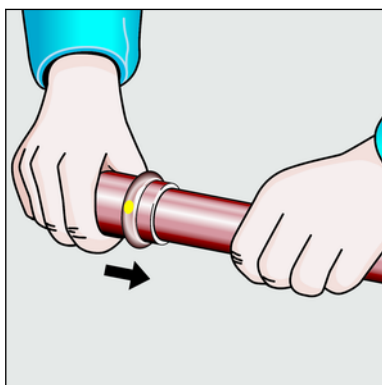

- Push the press connector onto the pipe as far as it will go.

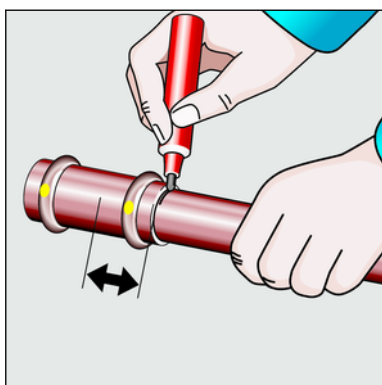

- Mark the insertion depth.

- Place the press jaw onto the press machine and push the retaining bolt in until it clicks into place.

INFO! Observe the press tool instruction manual.

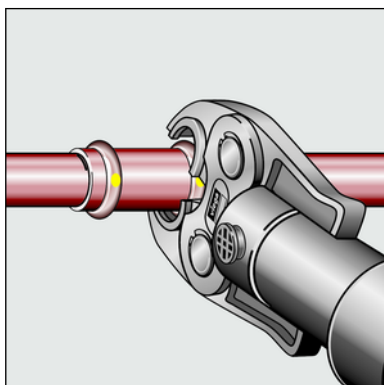

- Open the press jaw and place at a right-angle onto the connector.
- Check the insertion depth using the marking.
- Ensure that the press jaw is placed centrally on the bead of the press connector.

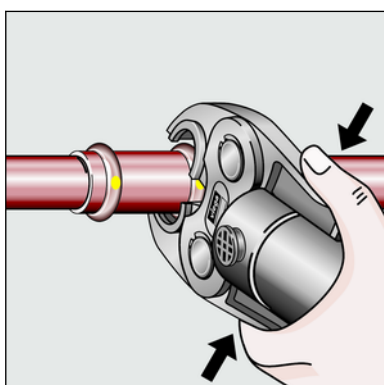

- Carry out the pressing process.

- Open and remove the press jaw.
 - ⇒ Connection is pressed.

3.4.6 Leakage test

The installer must perform a leakage test before commissioning.

This test is carried out on a system that is finished but not yet covered.

Observe the applicable regulations, see ↗ „Regulations from section: Leakage test“ on page 8.

Document the result.

3.5 Maintenance

Gas installations must be given a visual inspection, e. g. by the owner, once a year.

Serviceability and leak tightness must be checked every twelve years by an installation contractor.

To be covered by the warranty and to ensure the safe operation of the gas installations, operate and maintain them as intended, see ↗ „Regulations from section: Maintenance“ on page 8.

3.6 Disposal

Separate the product and packaging materials (e. g. paper, metal, plastic or non-ferrous metals) and dispose of in accordance with valid national legal requirements.