

GOK

Komponenten • Lösungen • Systeme



Data sheet – Compression fittings (DG-4502CM0253)

Data sheet - Compression fittings

Compression fittings - also described as solderless pipe fittings with olive - are intended for a secure and tight connection of pipes with straight ends or hose fittings.

	<p>Fittings and components may be connected to pipes or hoses with their tapped holes by means of screw-in connectors.</p> <p>Numerous designs with straight and angled forms, with screw-in or screw-on threads, with weld-on or pipe sockets and in different materials allow easy planning and installation of piping. The main requirements for compression fittings are now regulated in EN ISO 8434-1 or in DIN 2353 in the Federal Republic of Germany.</p> <p>A large number of standards and regulations allow compression fittings to be substituted in various applications according to applicable installation and building regulations.</p> <p>GOK compression fittings comply with the requirements of EN ISO 8434-1, DIN 2353 and DIN 3859-1.</p> <p>In general, these GOK compression fittings contain olives form A according to DIN 3861 - so-called single-bite olives.</p>
<p>Before tightening the coupling nut</p>  <p>After tightening the coupling nut</p> 	<p>Function</p> <p>For fittings according to EN ISO 8434-1 or DIN 2353 (24° cone connection). When the coupling nut is tightened, the olive with its preformed and hardened cutting edge ① is guided along the 24° inner cone of the fitting socket and is tapered. When it catches the pipe, it slides on the inner cone, penetrates the pipe with its cutting edge and creates a visible collar ④ in front of it. It is essential that the pipe ②, which has been sawn off at a right angle, butts against the end stop in the joint socket, as otherwise the olive cannot cut into the pipe.</p> <p>The inner form of the olive ③ ensures secure support of the pipe against vibration. The pipe connection created in this manner guarantees high operational safety.</p>

Table 1: Materials

All compression fittings are available in the materials named in DIN 3859-1.

Can be used for pipes made from	Compression fittings				
	Abbreviations			Names of material types used	
	GOK	DIN 3859-1	EN ISO 8434-1	Short name	Material no.
Steel	St steel	St	St	11SMn30, 11SMn-Pb30 11SMn37, 11SMn-Pb37	1.0715, 1.0718 1.0736, 1.0737
Copper and copper alloys	Br brass	Br	B	CuZn39Pb3 CuZn40Pb2	CW614N CW617N
Stainless steel	X stainless steel	V	SS	X6CrNiMoTi17-12-2	1.4571

Data sheet - Compression fittings

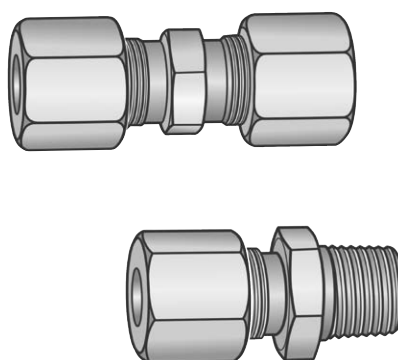
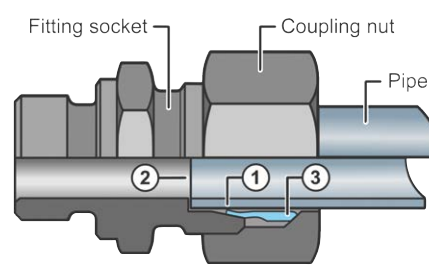
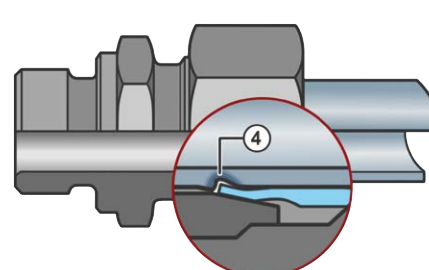
Table 2: Maximum permitted pressure PS

At temperatures of the operating medium TO (minimum and maximum) for compression fittings in the material pairs according to DIN 3859-1 the following maximum permitted pressures PS apply¹⁾:

Series		OD in mm	St steel		X stainless steel		Br Brass	
Description	Symbol		PS	Temperature TO	PS	Temperature TO	PS	Temperature TO
Very light	VL	4 to 8	100 bar	-20 °C to +120 °C	100 bar	-60 °C to +20 °C	63 bar	-40 °C to +175 °C
Light	L	6 to 15	250 bar		250 bar		160 bar	
		18 to 22	160 bar		160 bar		100 bar	
		28	100 bar		100 bar		63 bar	
Heavy	H	6 to 12	630 bar		630 bar		400 bar	
		16 to 25	400 bar		400 bar		250 bar	

Explanations:

- When using a brass olive type D-MS in a steel compression fitting, the maximum permitted pressure PS for brass and the temperature range TO -20 °C to +120 °C apply.
- When using it as a smooth pipe connector according to DIN 3387-1 in the DVGW [German Technical and Scientific Association for Gas and Water] area gas applies to MOP²⁾ / PS :
 - according to this table, but may not exceed 250 bar, or 25 bar in case of a brass olive type D-MS in a steel compression fitting
 - Working temperature TO from -20 °C to +60 °C.
- Maximum permitted pressure PS may be subject to restrictions that are listed in the applicable illustrated price list for the compression fitting and in the data sheet for screw-in connectors.
- Assignment of screwed plugs to screw-in holes see data sheet for screw-in connectors.

Table 3: Maximum permitted pressure PS of stainless steel compression fittings

Maximum permitted pressures PS in relation to the temperature of the operating medium for compression fittings in the material pair stainless steel according to DIN 3859-1.

Series		OD in mm	Maximum permitted pressure PS	PS at temperature TO from ... in bar		
Description	Symbol			+50 °C	+100 °C	+200 °C
Very light	VL	4 to 8	100 bar	96	89	80
Light	L	6 to 15	250 bar	240	222	200
		18 to 22	160 bar	153	142	128
		28	100 bar	96	89	80
Heavy	H	6 to 12	630 bar	604	560	504
		16 to 25	400 bar	384	356	320

¹⁾ Explanation about the maximum permitted pressure PS: ISO 8434-1 as an international standard with the term "maximum working pressure"; EN ISO 8434-1 term "maximum operation pressure"; DIN 3859-1 term "compressive strength". EN 764-1 uses "Maximum permitted pressure PS" and "operating pressure PO"

²⁾ DIN 3387-1 term "Maximum permitted operating pressure MOP" corresponding to the value PS in bar according to Directive 97/23/EC.

Explanations:

- Pressure reductions according to DIN 3859-1 / EN ISO 8434-1;
- Intermediate temperatures can be determined by interpolation;
- When using it as a smooth pipe connector according to DIN 3387-1 in the DVGW gas area:
 - Maximum permitted operating pressure MOP / PS, but may not exceed 250 bar;
 - Operating temperature TO from -20 °C to +60 °C.

Data sheet - Compression fittings

Table 4: Maximum permitted pressure PS depending on the thread size for screw-in connectors according to EN ISO 8434-1 and DIN EN ISO 1179 parts 1-4 with cylindrical male thread.

Series		OD in mm	Pipe thread according to EN ISO 228-1	St steel, X stainless steel		Br Brass				
Description	Symbol			PS	Temperature TS	PS	Temperature TS			
					St	X				
Very light	VL	4 to 8	G 1/8 A	100 bar	-20 °C to +120 °C	-60 °C to +20 °C	63 bar	-40 °C to +175 °C		
Light	L	6	G 1/8 A	250 bar						160 bar
		8 and 10	G 1/4 A							
		12	G 3/8 A							
		15	G 1/2 A	160 bar						
		18	G 1/2 A							
		22	G 3/4 A							
		28	G 1 A	100 bar						63 bar
Heavy	H	6 and 8	G 1/4 A	400 bar						400 bar
		10 and 12	G 3/8 A							
		16	G 1/2 A							
		20	G 3/4 A							
		25	G 1 A	250 bar	250 bar					

Explanations:

- When using a brass olive in a steel compression fitting, the maximum permitted pressure PS for brass and the temperature range TO -20 °C to +120 °C apply.
- When using a screw-in connector with elastomer gasket - O ring, profile sealing ring - the temperature range from -20 °C to +120 °C applies.
- When using an unhardened olive type DU in steel and brass compression fittings, the maximum permitted pressure is PS 6 bar.
- When using it as a smooth pipe connector according to DIN 3387-1 in the DVGW [German Technical and Scientific Association for Gas and Water] gas area:
 - according to this table, but may not exceed 250 bar;
 - 25 bar maximum in case of a brass olive type D-MS in a steel compression fitting or unhardened steel olive;
 - Screw-in connector in short design 25 bar maximum.

Maximum permissible pressure PS for assembled screw-in connectors:

- See data sheet for screw-in connectors.
- Maximum permissible pressure for cone-shaped screw-in connectors R-Rp limited to PS 16 bar.

Surface protection of the steel compression fitting



The surface of the **fitting sockets** and **coupling nuts** of the steel compression fitting has **chrome VI-free** surface protection applied in the factory. The short term for it is "**zinc-plated**".

The **steel olives** in compression fittings also have **chrome VI-free** surface protection and come in different designs:

- Hardened olive type D: "zinc-plated";
- Unhardened olive type DU: "zinc-plated", yellow.

Data sheet - Compression fittings

Table 5: Minimum length for straight pipe ends in pipe elbows H_{min} and minimum length of straight pipes L_{min}

		<p>The straight pipe end may not have any deviation in roundness or straightness in excess of the dimensional tolerances of the pipe according to DIN EN 10305-1 parts 1-4 and 6 or DIN EN 1057 in the full range of $2 \times H_{min}$.</p> <p>H_{min} according to DIN 2353</p>							
OD in mm	4	6	8	10	12	15	18	22	28
H_{min} in mm	19	25	25	26	26	28	30	32	34
L_{min} in mm	30	39	39	42	42	45	48	53	53

Table 6: Tightening torque for screw-in connectors

OD in mm	Pipe thread according to EN ISO 228-1	Tightening torque in Nm	Note
4 and 6	G 1/8 A	20	<p>The values stated apply to screw-in connectors with cylindrical steel screw-in studs, zinc-plated surface, counter body with tapped hole also made from steel. Use a suitable gasket.</p> <p>The values stated do not apply to screw-in connectors with cone-shaped pipe thread R according to DIN 3858 or EN 10226-1 or with NPT thread according to ANSI B1.20.1-1983. For these threaded connections seal tightness is achieved by the tightening torque in connection with additional sealing materials.</p>
8 and 10	G 1/4 A	40	
12	G 3/8 A	80	
15 and 18	G 1/2 A	140	
22	G 3/4 A	180	
28	G 1 A	300	